

# **Development of Battery Management and User Interface Systems for Consumer Electronic Applications**

## **Investigator:**

Dr. R Kalpana

Asst. Professor, Department of Electrical and Electronics Engineering,

National Institute of Technology, Karnataka, Surathkal,

Email: kalpana@nitk.edu.in

## **Overview of the Project:**

Due to unreliable grid power supply, most of the consumers are moving towards the photovoltaic (PV) roof top systems for a backup source of supply. Since the PV is intermittent, batteries are the most vital parameter in any PV roof top systems and the cost of these batteries are high compared to other components in the whole system. Moreover, most of the cases, before the PV system reaches to its end of life, batteries get damage due to improper operation and maintenance. Therefore, this increases the recurring cost of system as the battery has to be replaced multiple times. Therefore, it would be advantageous if the consumer knows the safe operating conditions and present state of health of the battery. In India, Li-Ion battery market has been emerging and also it has surpassed 1GWh Li-Ion battery deployment in the applications like telecom BTS stations and ATM machines [1, 2]. According to NITI Aayog's energy storage report [3], India is anticipating 120GWh cumulative battery requirement by year 2020.

Lithium ion batteries have become popular choice over other rechargeable batteries due to its longer life cycle and compact size. However, Li-Ion batteries are intolerant to overcharge and deep discharges. Therefore, these batteries require a management system to operate batteries in safe operating conditions, which indicates the necessity of developing an accurate battery management system(BMS).

The BMS available in market give only information related to state of charge (SOC). Hence, consumer will not be knowing the present health condition of the battery and correct time to replace the battery. Therefore, this project is aimed to develop a battery management system, which gives the information of battery state of charge (SOC), battery state of health (SOH) and safe operating conditions. Moreover, a serial communication system with the computer will be developed in this project which displays the battery management system parameters such as SOC and SOH.

The multiport converter can interface three different ports, i.e. battery, PV panels and the load. The centralized architecture of multiport converters uses fewer switches, has compact structure, lower cost, higher efficient. It allows operation as a single input single-output (SISO), dual-input-single-output

(DISO) and single-input-dual-output (SIDO) converter. It is directly derived from common and well known buck and boost topologies. The control strategy to the switches includes three regulators. First is output voltage controller(OVC) which maintains the output at fixed level. Second is SOC controller which prevents the battery overcharge and deep discharge. Third is MPPT controllers, which operates the PV at maximum power point. The high ripple in input current and output voltage is reduced by using the interleaved inductors. The efficiency of the converter is further increased by using Zero Voltage Switching(ZVS) resonance topology. The battery is operated at constant voltage mode where the SOC of the battery is measured by using the coulomb counting method by integrating the charge/discharging current.

**Objectives of the project:**

The main objective of this proposal is to develop an online method to estimate the SOH and SOC of the lithium iron phosphate battery deployed in PV rooftop systems and to develop a user interface system to display estimated SOC and SOH parameters. To accomplish this main objective, some of the important tasks to complete are identified and listed below.

1. Development of an accurate mathematical model of the lithium iron phosphate battery being used.
2. Investigation of effect of stress factors, such as maximum charging voltage, DoD, charge/discharge rates and operating temperature on battery life.
3. Development of accurate SOC and SOH estimation methods for PV powered battery charging system.
4. Validating the developed SOC and SOH methods experimentally.
5. Developing a GUI to display SOC and SOH information to the consumer.

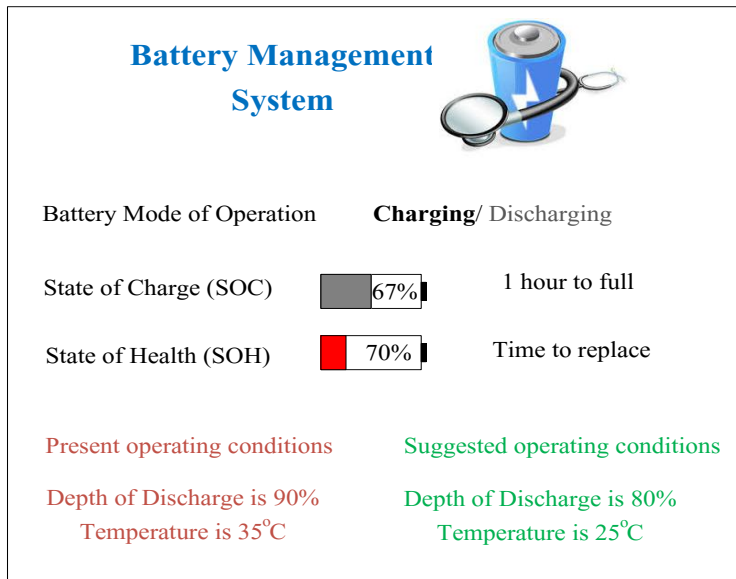

Fig. 1. Expected GUI of battery management system

## Key Deliverables / Outcomes

1. A complete battery management system will be delivered with all commercial features (including GUI)
2. Filing patents
3. Publications in the reputed international/national journals
4. Students (B.Tech/M.Tech) who work on this project will get the exposure of power electronics and embedded systems.
5. Developed battery management system will be deployed for batteries used in NITK laboratories as a backup source.

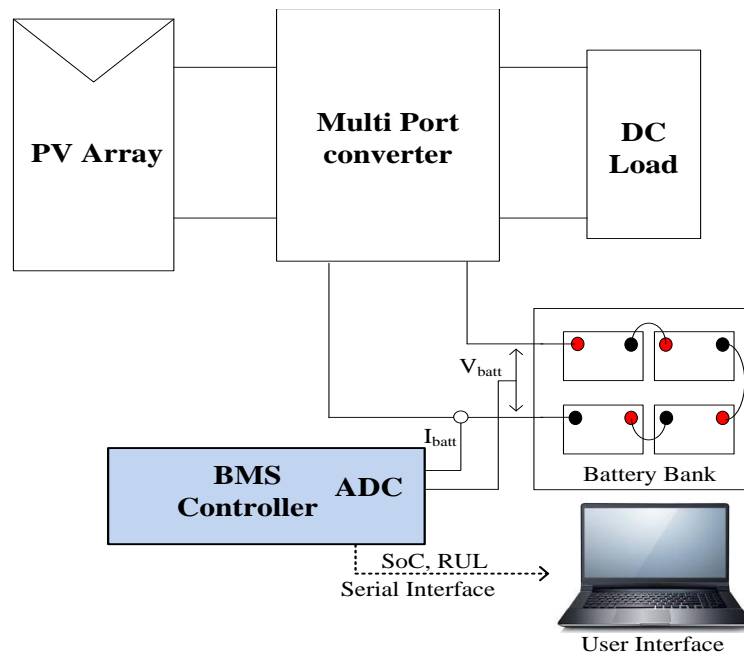

Fig. 2. Schematic of the proposed battery management system

### Estimated Cost:

#### Details of Financial Requirement:

Sl.No	Item	Cost (Rs.)
1	Consumables and Contingencies	80,000
3	Equipments	2,25,000
<b>Total</b>		<b>3,05,000</b>

### **Justification for the consumables and contingency cost**

Consumable and contingency includes the electronic circuitry, soldering items, papers, printer cartridge, fabrication charges, buying books (if necessary) and other stationary items.

### **Budget for equipment**

<b>Sl.No</b>	<b>Item</b>	<b>Cost (Rs.)</b>
1	32bit microcontroller development board (including debugger)	50,000
2	DC programmable load or battery discharge tester	1,75,000
<b>Total</b>		<b>2,25,000</b>

### **Justification for the equipment required**

Bidirectional DC-DC converter charges and discharges the battery, this converter is used to control the parameters and to start/stop the charge/discharge process.

32bit microcontroller is to implement the developed SOC and SOH algorithm, also this controller communicates with the GUI.

Programmable DC Load can be used to discharge the battery with different ‘C’ rates, also it measures the run time characteristics of battery being discharged. This equipment mainly helps in analyzing battery ageing pattern and to validate the developed SOH algorithm.

### **References:**

- [1] R. Spurrett, “The Future of Lithium-ion space batteries”, NASA Battery Workshop, 2008.
- [2] “India Lithium-ion Battery Market Forecast and Opportunities, 2020” Jan, 2015.
- [3] Shikha Juyal, Harkiran Sanjeevi, Shashvat Singh and Anil Srivastava “INDIA’S ENERGY STORAGE MISSION: A Make-in-India Opportunity for Globally Competitive Battery Manufacturing”, NITI Aayog and Rocky Mountain Institute, 2017.

### **Investigator Bibliography:**

Dr. R Kalpana received the Bachelor of Engineering (Electrical and Electronics) degree from Madras University, Chennai, India, in 1998, and M.E (Power Systems) from Anna University, Chennai, India, in 2000. She received the Ph.D. degree in Electrical engineering from Indian Institute of Technology Delhi, India, in 2012. She is currently working as Assistant professor in the Department of Electrical and Electronics Engineering, National Institute of Technology, Karnataka, India. Her areas of

interest include power systems, power electronics, flexible ac transmission system, power conditioning and battery health prognostic techniques.

### **Key publications of the Investigator**

#### Patents filed

- [1] Indian Patent filed on “Method and System for Maximum Power Point Tracking of a PV- Array during Non-Uniform Insolation Conditions” Application No: TEMP/E-1/17658/2017-CHE dt: May 17, 2017.
- [2] Indian Patent filed on “A multiphase transformer rectifier unit and a method thereof” Application No: 201641040621, filed November 2016.

#### International Journals in last 5 years

- [1] J. S. Goud, R. Kalpana and B. Singh, "A Hybrid Global Maximum Power Point Tracking Technique with Fast Convergence Speed for Partial Shaded PV Systems," *IEEE Transactions on Industry Applications*. doi: 10.1109/TIA.2018.2845415.
- [2] S. P. P, K. R, B. Singh and G. Bhuvaneshwari, "Power Quality Improvement in Utility Interactive Based AC-DC Converter Using Harmonic Current Injection Technique," *IEEE Transactions on Industry Applications*. doi: 10.1109/TIA.2018.2855142.
- [3] R. Kalpana, S. C. Khimavath, S. P. P and B. Singh, "Power Quality Enhancement Using Current Injection Technique in a Zigzag Configured Autotransformer Based 12-Pulse Rectifier," *IEEE Transactions on Industry Applications*. doi: 10.1109/TIA.2018.2851566
- [4] S. P. P; R. Kalpana; B. Singh; G. Bhuvaneshwari, "A 20-Pulse Asymmetric Multi-Phase Staggering Autoconfigured Transformer for Power Quality Improvement," *IEEE Trans. on Power Electronics* , 2017.
- [5] V. V S; R. Kalpana; B. Singh; S. Prakash P, "Improvement in Harmonic Reduction of Zigzag Autoconnected Transformer Based 12-pulse Diode Bridge Rectifier by Current Injection at DC Side," *IEEE Trans. on Industry Applications* , 2017.
- [6] R. Kalpana, G. Bhuvaneshwari and Bhim Singh, “Harmonic Reduction in 20-Pulse AC-DC Converter fed Switched Mode Power Supplies,” *IEEE Trans. on Ind. Electron.*, vol. 60, no. 10, pp. 4178-4190, Oct. 2013.